

ACADEMY

MONITOR ARM SERIES



Grand Stands

Ergonomic Workstation Solutions

Since 1991 - Pioneers, Designers & Manufacturers of the Finest Custom Ergonomic Solutions

One-way Friction Lock Technology

The Academy Series introduces industry changing ONE-WAY Friction Lock Technology. The ACE15 features 15" of height range that greatly exceeds the industry standard 10" to 13". Our patented design and intelligent engineering provides ease of use and stability when typing.



Features

- ▶ 15" Vertical Height Range w/ No Ugly Pole
- ▶ Tilt Adjustment, Swivels Portrait to Landscape
- ▶ 23.6" Front to Back Distance, Compacts to 4"
- ▶ VESA Compliant
- ▶ Clamp and Grommet Mount Included
- ▶ 0 to 20 Pounds of Supported Weight Capacity For Single Monitor
- ▶ Very Stable and Limited Bounce When The User is Typing
- ▶ Standard Color Silver (-S) Black Available (-B) and White (-W)
- ▶ Internal Cable Management
- ▶ 10-Year Warranty
- ▶ Easy Installation - Ships Assembled

ACE15-S *Single Monitor Arm (Silver) List Price \$340.00*

ACE15-B *Single Monitor Arm (Black) List Price \$340.00*

ACE15-W *Single Monitor Arm (White) List Price \$340.00*

Available Colors



Silver

Black

White

Mounting Options

Clamp & Grommet Included

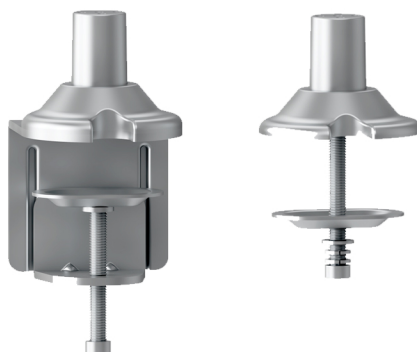

www.grandstands.com

ACE15

Monitor Arm System

(800) 831.2150

ACADEMY

MONITOR ARM SERIES



Grand Stands

Ergonomic Workstation Solutions

Since 1991 - Pioneers, Designers & Manufacturers of the Finest Custom Ergonomic Solutions

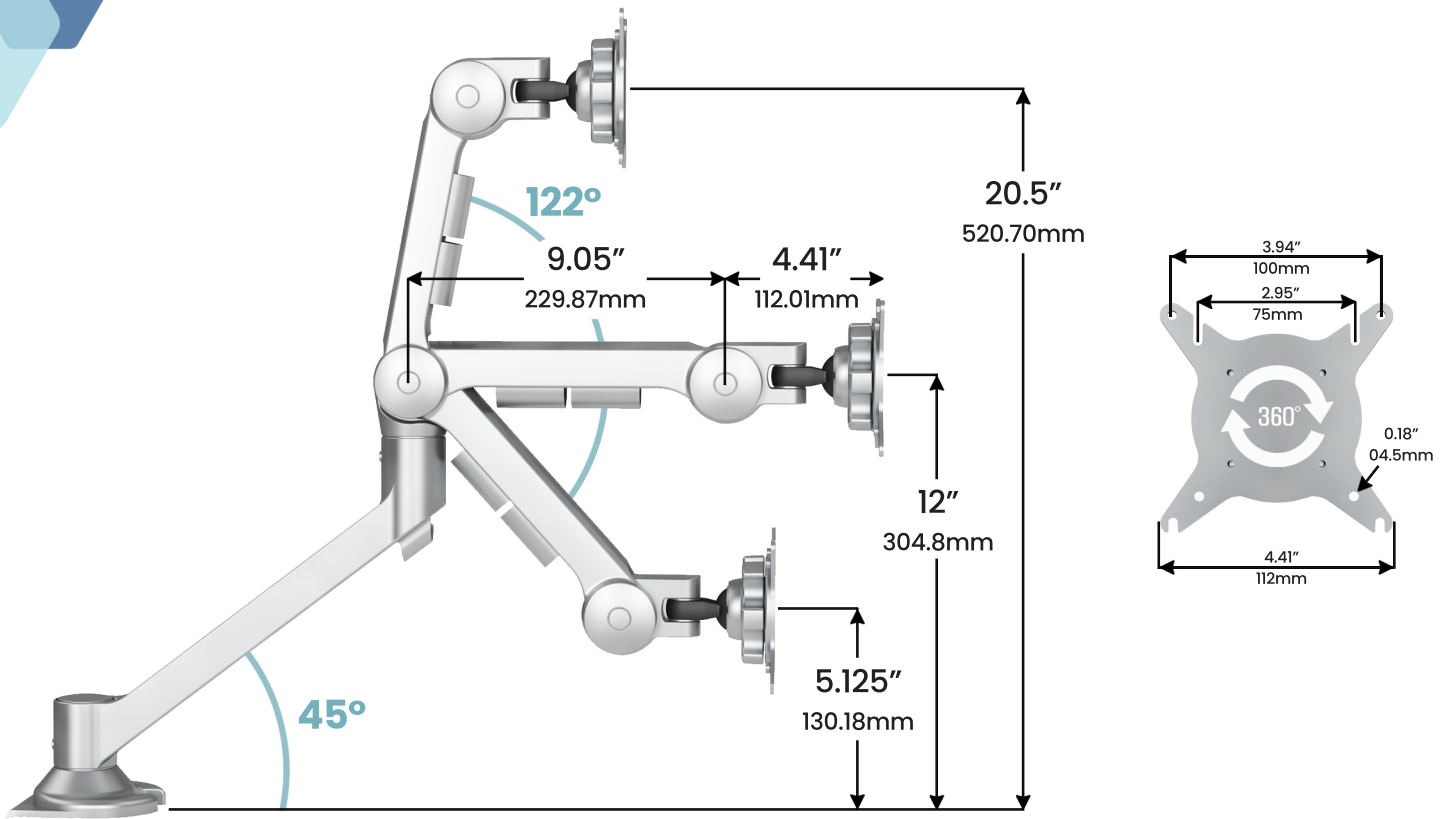

ACE15

Mounting Options

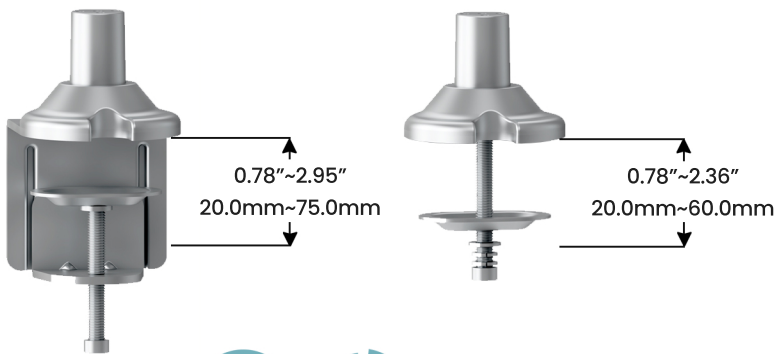

- Height Range: 15"
- Maximum Extension From Post: 23.6"
- Depth From Post (Closed): 0"
- Tilt Adjustment: $\pm 15^\circ$
- Display Pan Swing - Side to Side: 180°
- VESA Compatibility: 75x75mm/100x100mm
- Weight Capacity: 0-20 lbs.

