

Grand Stands: CPU Holders

The CPU is the second most important tool in your office next to your employees. Where do you put this important tool? The work surface is valuable space and the floor makes the CPU susceptible to dust, static electricity and the vacuum cleaner. The CPU is too important a tool to put on the floor. The CPU Support allows you to utilize the wasted space under the desk; the swivel and slide feature keep it accessible.

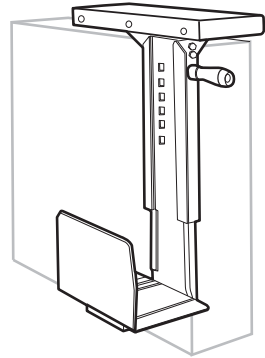

9650CP CPU Support - Black

- Accommodates medium to large CPU sizes
- Height adjustment from 9¼" to 13¼," width adjustment from 5¼" to 9¼"
- 360° degree swivel for rear port access
- 13½" ball-bearing track can be mounted parallel or horizontal to the work surface

List: **195.00**

9650CPS CPU Support - Silver

- Accommodates smaller CPU sizes
- Height adjustment from 9¼" to 13¼," width adjustment from 3" to 5¼"
- 360° degree swivel for rear port access
- 13½" ball-bearing track can be mounted parallel or horizontal to the work surface

List: **195.00**

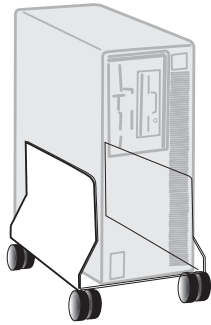

9950CP CPU Trolley

- Protects the CPU from dust and static electricity
- Mobile for easy access of rear ports
- Adjusts to fit most CPU sizes

List: **95.00**

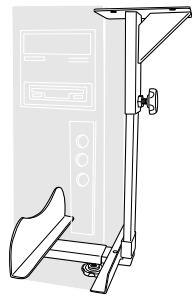

9900CP Convertible CPU Holder

- Simple assembly
- Under desk mount that does not retract
- Adjusts from:
Vertical: adjusts from 15½" to 20" height,
5½" to 10" width
Horizontal: adjust from 7.3" to 11.3" height,
13.8" to 18.6" width

List: **125.00**

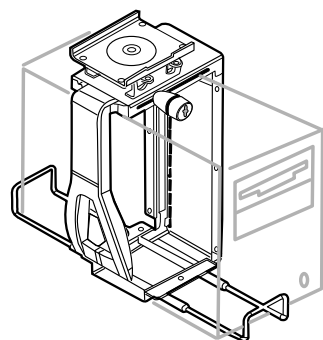
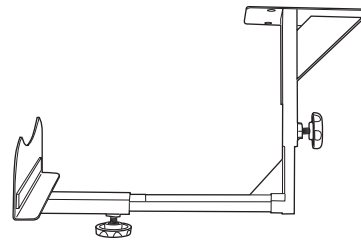

9250CP Lock and Store CPU Holder

- Lockable CPU holder with soft touch knob and lock
- Load rating up to 85 lbs.
- 360° degree swivel for rear port access
- Retractable on 18" glide track

List: **295.00**

Grand Stands Terms and Conditions

Terms:

1% 10, net 30, from date of shipment, upon approved credit. All other orders will be shipped COD or prepaid. We accept Visa and MasterCard. A 50% deposit is required on all custom orders and standard orders over \$5,000.

Freight:

Free standard ground freight on products ordered from this price book shipped anywhere in the continental United States. Please call for quotes on shipping outside the continental United States, expedited freight service, and for products not listed in this price book, i.e., adjustable tables, work surfaces, etc.

Transit Damage:

Grand Stands is not responsible for damage to our products which occurs in transit or in storage. It is the customer's responsibility to examine products upon receipt. Note any damage in transit on the carrier's delivery receipt. In case of obvious damage, such as a torn or crushed box, refuse shipment and Grand Stands will handle the freight claim and replace your order. *In case of suspected damage follow these steps:*

1. Receive the shipment and note on bill of lading "possible concealed damage"
2. OR refuse shipment if there is apparent damage. We will replace your order and file for freight claim.

Returns:

A return authorization number must be obtained from Grand Stands, Inc., and should be referenced on all packages. Product must be in original condition and packaging for a refund. Delivery freight charges will not be refunded. 10% restocking fee applies to any orders returned within 10 days. A 25% restocking charge will be applied if merchandise is returned more than 10 days after purchase. Customer is responsible for return freight.

Prices:

Pricing is effective **January 1, 2009** and supercedes all previous price lists. Prices are subject to change without notice.

Warranty:

Limited Lifetime warranty in the event of a defect in material or workmanship. Grand Stands, Inc., will repair or replace the defective item free of charge within the U.S.A.

This warranty is extended only to the original purchaser. Proof of purchase will be required before warranty is honored.

The warranty only covers failures due to defects in material and workmanship which occurred during manufacturing. It does not cover damage caused by shipping, failures caused by products not supplied by Grand Stands, Inc., failures resulting from accident, misuse, abuses, neglect, mishandling, modification, damage attributable to acts of God or service by anyone other than authorized Grand Stands, Inc., service/repair personnel.

Limits and Exclusions:

There are no express warranties except as listed.

Grand Stands, Inc., shall not be liable for special, consequential, incidental, or punitive damages, including but not limited to: loss of goodwill, profits, revenue, loss of the use of this product, or any associated equipment, downtime costs, or claims resulting from the use of this product or arising from breach of the warranty contract.

Total liability of Grand Stands, Inc., shall not exceed the purchase price of the part upon such liability is based.

